

A New Approach to Find Shortest Path in Intuitionistic Fuzzy Environment

G. Sudha^{1,*} and R. Sophia Porchelvi²

¹ Department of Mathematics, A.V.C. College (Autonomous), Mannampandal, Tamil Nadu, India.

² Department of Mathematics, A.D.M College for women (Autonomous), Nagapattinam, Tamil Nadu, India.

Abstract: This paper presents to find the shortest path in a directed graph which an Triangular Intuitionistic Fuzzy Number, instead of a fuzzy number is assigned to each arc length. Procedures are designed to find the optimal path. An illustrative example is given to demonstrate the proposed approach.

Keywords: Shortest path, Triangular Intuitionistic Fuzzy Number (TIFN), Chen and Cheng Metric distance, Fuzzy network.

© JS Publication.

1. Introduction

The Shortest path problem is a classical network optimization problem in which the weights of the edges in a SPP are supposed to be real numbers. In such cases it is quite appropriate to use fuzzy numbers for modelling the problem which gives rise to Fuzzy Shortest Path Problem (FSPP). Fuzzy set theory proposed by Zadeh (1978) is an effective tool to take the problems of uncertainty. Determination of shortest distance and shortest path between two vertices is one of the most fundamental problems in graph theory. Let $G = (V, E)$ be a graph with V as the set of vertices and E as the set of edges. A path between two vertices is an alternating sequence of vertices and edges starting and ending with vertices, and no vertices or no edges appear more than once in the sequence. The length of a path is the sum of the weights of the edges on the path. There may exist more than one path between a pair of vertices. The SPP is one of the most fundamental and well-known combinatorial optimization problems that appears in many applications as a sub-problem. The length of arcs in the network represents travelling time, cost, distance or other variables. In 1980 Dubois and Prade [4] first introduce fuzzy SPP. Okada and Soper [6] developed an algorithm based on multiple labeling approaches which is useful to generate number of non-dominated paths. Applying minimum concept they have introduced an order relation between fuzzy numbers. Applying extension principle Klein [5], has given an algorithm which results dominated path on a acyclic network. This paper is organized as follows. In section 2, some preliminary concepts and definitions are given. The procedure for finding shortest path using TIFN is developed in section 3. An illustrative example is provided in section 4 to find the shortest path from a specified node to every node in a network having imprecise weights. The last section draws some concluding remarks.

* E-mail: venkat_sudha@yahoo.in

2. Prerequisites

Definition 2.1 (Fuzzy Set). A fuzzy set \tilde{A} is defined by $\tilde{A} = \{(x, \mu_A(x)) : x \in A, \mu_A(x) \in [0, 1]\}$. In the pair $(x, \mu_A(x))$ the first element x belongs to the classical set A , the second element $\mu_A(x)$, belongs to the interval $[0, 1]$, called Membership function. It can also be denoted by $\tilde{A} = \{\mu_A(x)/x : x \in A, \mu_A(x) \in [0, 1]\}$, where symbol ‘/’ is not a division sign but indicates that the top number $\mu_A(x)$ is the membership value of the element x in the bottom.

Definition 2.2 (Fuzzy Number). The notion of fuzzy numbers was introduced by Dubois [4]. A fuzzy subset A of the real line R with membership function $\mu_A : R \rightarrow [0, 1]$ is called a fuzzy number if

- (1). A is normal, i.e., there exists an element $x_0 \in A$ such that $\mu_A(x_0) = 1$.
- (2). A is fuzzy convex, i.e., $\mu_A(\lambda x_1 + (1 - \lambda)x_2) \geq \mu_A(x_1) \wedge \mu_A(x_2) \forall (x_1, x_2) \in R$ and $\forall \lambda \in [0, 1]$.
- (3). μ_A is upper semi continuous.
- (4). $Supp A$ is bounded where $Supp A = \{x \in R : \mu_A(x) > 0\}$.

Definition 2.3 (Triangular Fuzzy Number). A triangular fuzzy number \tilde{A} is a fuzzy number fully specified by 3-tuples (a_1, a_2, a_3) such that $a_1 \leq a_2 \leq a_3$, with membership function defined as

$$\mu_{\tilde{A}}(x) = \begin{cases} \frac{x-a_1}{a_2-a_1}, & \text{if } a_1 \leq x \leq a_2 \\ \frac{a_3-x}{a_3-a_2}, & \text{if } a_2 \leq x \leq a_3 \\ 0, & \text{otherwise} \end{cases}$$

This is represented diagrammatically as

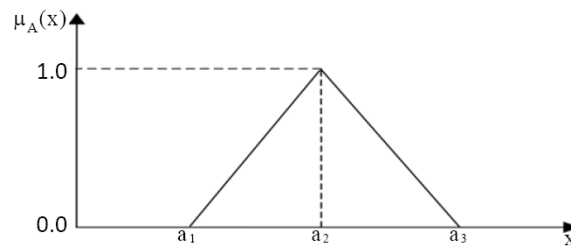

Figure 1. Triangular fuzzy number

Definition 2.4. Suppose $\tilde{A} = (a_1, a_2, a_3)$ and $\tilde{B} = (b_1, b_2, b_3)$ are two triangular fuzzy numbers. Then the fuzzy arithmetic operations under function principle introduced by Chen [2] are furnished below.

Addition:

$$\tilde{A} + \tilde{B} = (a_1 + b_1, a_2 + b_2, a_3 + b_3),$$

where a_1, a_2, a_3, b_1, b_2 and b_3 are any real numbers.

Subtraction:

$$\tilde{A} - \tilde{B} = (a_1 - b_1, a_2 - b_2, a_3 - b_3),$$

where a_1, a_2, a_3, b_1, b_2 and b_3 are any real numbers.

Definition 2.5 (Intuitionistic Fuzzy Set (IFS)). Let X be the universe of discourse, then an intuitionistic fuzzy set A in X is given by $A = \{x, \mu_A(x), \gamma_A(x) / x \in X\}$ where $\mu_A(x) : X \rightarrow [0, 1]$ and $\gamma_A(x) : X \rightarrow [0, 1]$ determine the degree of membership and non membership of the element $x \in X$, respectively and for every $x \in X, 0 \leq \mu_A(x) + \gamma_A(x) \leq 1$.

Definition 2.6 (Intuitionistic Fuzzy Graph). Let X be the universe, containing fixed graph vertices and let $V \subset X$ be a fixed set. Construct the IFS $V = \{x, \mu_v(x), \gamma_v(x) / x \in X\}$ where the functions $\mu_v(x) : X \rightarrow [0, 1]$ and $\gamma_v(x) : X \rightarrow [0, 1]$ determine the degree of membership and non membership to set V of the element(vertex) $x \in X$, respectively and for every $x \in X, 0 \leq \mu_v(x) + \gamma_v(x) \leq 1$.

Definition 2.7 (Intuitionistic Fuzzy Number (IFN)). Let be $A = \{(x, \mu_A(x), \gamma_A(x)) / x \in X\}$ an IFS, then we call the pair $(\mu_A(x), \gamma_A(x))$ an intuitionistic fuzzy number. We denote an intuitionistic fuzzy number by $(\langle a, b, c \rangle, \langle l, m, n \rangle)$, where $\langle a, b, c \rangle \in F(I), \langle l, m, n \rangle \in F(I), I = [0, 1], 0 \leq c + n \leq 1$.

2.1. Triangular Intuitionistic Fuzzy Number (TIFN) and its Arithmetic

A TIFN 'A' is given by $A = \{(\mu_A, \gamma_A) / x \in R\}$, where μ_A and γ_A are triangular fuzzy numbers with $\gamma_A \leq \mu_A^c$. So a triangular intuitionistic fuzzy number A is given by $A = (\langle a, b, c \rangle, \langle e, f, g \rangle)$ with $\langle e, f, g \rangle \leq \langle a, b, c \rangle^c$ i.e., either $e \geq b$ and $f \geq c$ or $f \leq a$ and $g \leq b$ are membership and non-membership fuzzy numbers of A. An intuitionistic fuzzy number $(\langle a, b, c \rangle, \langle e, f, g \rangle)$ with $e \geq b$ and $f \geq c$ is shown in the following figure:

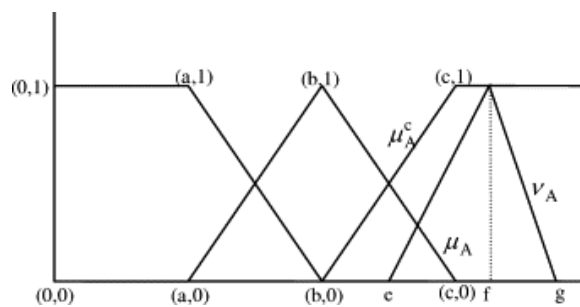

Figure 2. Triangular intuitionistic fuzzy number

The additions of two triangular intuitionistic fuzzy numbers are as follows:

Addition: For two triangular Intuitionistic Fuzzy Numbers $A = (\langle a_1, b_1, c_1 \rangle : \mu_A, \langle e_1, f_1, g_1 \rangle : \gamma_A)$ and $B = (\langle a_2, b_2, c_2 \rangle : \mu_B, \langle e_2, f_2, g_2 \rangle : \gamma_B)$ with $\mu_A \neq \mu_B$ and $\gamma_A \neq \gamma_B$, define

$$A + B = (\langle a_1 + a_2, b_1 + b_2, c_1 + c_2 \rangle : \text{Min}(\mu_A, \mu_B), \langle e_1 + e_2, f_1 + f_2, g_1 + g_2 \rangle : \text{max}(\gamma_A, \gamma_B))$$

Subtraction:

$$A - B = (\langle a_1 - a_2, b_1 - b_2, c_1 - c_2 \rangle : \text{min}(\mu_A, \mu_B), \langle e_1 - e_2, f_1 - f_2, g_1 - g_2 \rangle : \text{Max}(\gamma_A, \gamma_B))$$

Where a_1, a_2, a_3, b_1, b_2 and b_3 are any real numbers.

2.2. Chen and Cheng Metric Distance Ranking [2]

Chen and Cheng [2] proposed a metric distance method to rank fuzzy numbers. Let A and B be two fuzzy numbers defined as follows:

$$g_A(x) = \begin{cases} g_A^L(x), & x < m_A \\ g_A^R(x), & x \geq m_A \end{cases}$$

$$g_A(x) = \begin{cases} g_B^L(x), & x < m_B \\ g_B^R(x), & x \geq m_B \end{cases}$$

where m_A and m_B are the mean of A and B. The metric distance between A and B can be calculated as follows:

$$D(A, B) = \left[\int_0^1 (h_A^L(y) - h_B^L(y))^2 dy + \int_0^1 (h_A^R(y) - h_B^R(y))^2 dy \right]^{\frac{1}{2}}$$

where h_A^L, h_A^R, h_B^L and h_B^R are the inverse functions of g_A^L, g_A^R, g_B^L and g_B^R respectively. In order to rank fuzzy numbers, Chen and Cheng [2] let the fuzzy number $B = 0$ then the metric distance between A and 0 is calculated as follows:

$$D(A, 0) = \left[\int_0^1 (h_A^L(y))^2 dy + \int_0^1 (h_A^R(y))^2 dy \right]^{\frac{1}{2}},$$

the larger value of $D(A, 0)$ is the better ranking of A. According to Chen and Cheng, the membership function of A is defined as follows:

$$f_A(x) = \begin{cases} \frac{x - (\mu - \sigma)}{\sigma}, & \text{if } \mu - \sigma \leq x \leq \mu \\ \frac{(\mu + \sigma) - x}{\sigma}, & \text{if } \mu \leq x \leq \mu + \sigma \end{cases}$$

where μ and s are calculated as follows: $\sigma = \frac{N-L}{2}, \mu = \frac{L+2M+N}{4}$ where A becomes a TIFN, $A = (\langle a, b, c \rangle, \langle p, q, r \rangle)$, $L = a + p; M = b + q; N = c + r$. The inverse functions h_A^L and h_A^R of g_A^L, g_A^R respectively, are shown as follows: $h_A^L(y) = (\mu - \sigma) + \sigma y; h_A^R(y) = (\mu + \sigma) - \sigma y$.

3. Proposed Algorithm

Algorithm for Triangular Intuitionistic Fuzzy SPP based on Chen and Cheng [2].

Metric distance Ranking

Step 1: Construct a network $G = (V, E)$ where V is the set of vertices E is the set of edges. Here G is an acyclic digraph and the arc length takes the Triangular Intuitionistic Fuzzy Numbers.

Step 2: Form the possible paths P_i from source vertex to the destination vertex and compute the corresponding path lengths L_i , using 2.1.

Step 3: Calculate the intuitionistic fuzzy path using 2.2.

Step 4: The path having the minimum rank is identified as the shortest path.

4. Illustrative Example

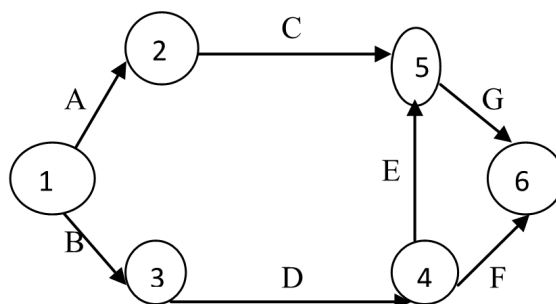

Consider a network with Triangular Intuitionistic fuzzy arc lengths as shown below. The arc lengths are assumed to be $A(1 - 2) = (\langle 2, 3, 4 \rangle, \langle 6, 8, 9 \rangle)$; $B(1 - 3) = (\langle 1, 2, 3 \rangle, \langle 4, 5, 6 \rangle)$; $C(2 - 5) = (\langle 5, 6, 7 \rangle, \langle 7, 8, 9 \rangle)$; $D(3 - 4) = (\langle 2, 4, 5 \rangle, \langle 5, 6, 7 \rangle)$; $E(4 - 5) = (\langle 4, 5, 6 \rangle, \langle 7, 9, 10 \rangle)$; $F(4 - 6) = (\langle 3, 4, 5 \rangle, \langle 6, 7, 8 \rangle)$; $G(5 - 6) = (\langle 6, 7, 8 \rangle, \langle 9, 10, 11 \rangle)$. The possible paths and its corresponding path lengths are as follows

Paths (P_i)	Lengths (L_i)
$P_1: 1 - 2 - 5 - 6$	$(\langle 13, 16, 19 \rangle, \langle 22, 26, 29 \rangle)$
$P_2: 1 - 3 - 4 - 5 - 6$	$(\langle 13, 18, 22 \rangle, \langle 25, 30, 34 \rangle)$
$P_3: 1 - 3 - 4 - 6$	$(\langle 6, 10, 13 \rangle, \langle 15, 18, 21 \rangle)$

To obtain the critical path using ranking procedure :

$$\begin{aligned}
 P_1 &= (\langle 13, 16, 19 \rangle, \langle 22, 26, 29 \rangle) \\
 \sigma &= \frac{N - L}{2} = \frac{48 - 35}{2} = 6.5 \\
 \mu &= \frac{L + 2M + N}{4} = \frac{35 + 2(42) + 48}{4} = 41.7 \\
 h_A^L(y) &= 35.2 + 6.5y \\
 h_A^R(y) &= 48.2 - 6.5y \\
 R(P_1) &= \left[\int_0^1 (35.2 + 6.5y)^2 dy + \int_0^1 (48.2 - 6.5y)^2 dy \right]^{\frac{1}{2}} = 59.2
 \end{aligned}$$

Similarly,

$$\begin{aligned}
 R(P_2) &= \left[\int_0^1 (39.3 + 9y)^2 dy + \int_0^1 (57.3 - 9y)^2 dy \right]^{\frac{1}{2}} = 68.7 \\
 R(P_3) &= \left[\int_0^1 (21.3 + 6.5y)^2 dy + \int_0^1 (34.3 - 6.5y)^2 dy \right]^{\frac{1}{2}} = 39.67
 \end{aligned}$$

Since $R(P_3) < R(P_1) < R(P_2)$. From the above, we can see that the path P_3 has the least value for membership and non-membership. The shortest path from source node to destination node is $1 - 3 - 4 - 6$.

5. Conclusion

In this paper, an algorithm is developed for solving SPP on a network with Triangular intuitionistic fuzzy arc lengths where the shortest path is identified using the concept of Chen and Cheng [2] ranking function with regard to the fact that the Decision Maker can choose the best path among various alternatives from the list of ranking.

References

[1] Amit Kumar and Manjot Kaur, *A new algorithm for solving network flow problems with fuzzy arc lengths*, An official journal of Turkish Fuzzy systems Association, 2(1)(2011),1-13.

[2] L.S.Chen and C.H.Cheng, *Selecting IS personnel using ranking fuzzy number by Metric distance method*, European Journal of Operations Research, 160(3)(2005), 803-820.

[3] T.N.Chuang and J.Y.Kung, *The fuzzy shortest path length and the corresponding shortest path in a network*, Computers and Operations Research, 32(6)(2005), 1409-1428.

[4] D.Dubois and H.Prade, *Fuzzy Sets and Systems: Theory and Applications*, Academic Press, New York, (1980).

- [5] C.M.Klein, *Fuzzy shortest paths*, Fuzzy Sets and Systems, 39(1)(1991), 27-41.
- [6] S.Okada and T.Soper, *A shortest path problem on a network with fuzzy arc Lengths*, Fuzzy Sets and Systems, 109(1)(2000), 129-140.
- [7] A.Nagoor Gani and A.Mumtaj Begam, *A New approach on shortest path in fuzzy environment*, ICTACT Journal on Soft Computing, 2(2010), 102-104.
- [8] R.Sophia Porchelvi and G.Sudha, *A modified algorithm for solving shortest path problem with Intuitionistic fuzzy arc lengths*, International Journal of Scientific and Engineering Research, 4(10)(2013), 844-847.
- [9] R.Sophia Porchelvi and G.Sudha, *Intuitionistic Fuzzy Critical path in a network*, International conference on Mathematical Methods and Computations, (2014).
- [10] R.Sophia Porchelvi and G.Sudha, *Computation of shortest path in a fuzzy network using Triangular Intuitionistic Fuzzy Number*, International Journal of Scientific and Engineering Research, 5(12)(2014), 1254-1257.
- [11] M.T.Takahashi and A.Yaamakani, *On fuzzy Shortest Path Problem with fuzzy parameter an algorithm*, American approach Proceedings of the Annual Meeting of the North Fuzzy Information Processing Society, (2005), 654-657.
- [12] J.S.Yao and K.M.Wu, *Ranking fuzzy numbers based on decomposition principle and signed distance*, Fuzzy Sets and Systems, 116(2000), 275-288.
- [13] L.A.Zadeh, *Fuzzy Sets*, Informat. Control, 8(1965), 338-353.